

How to Install a Silt Fence

Sediment runoff from a hill is one of the easiest ways to disrupt a construction site or pollute a fresh water source. Silt fences use a special material that catches the sediment and filters it out of the water. You should install a silt fence on the bottom of a slope if you're trying to restrict water runoff. To install a silt fence, you'll need wooden stakes and silt fence fabric. If you follow the correct steps, you can install an effective silt fence.

The **silt fence** is an ideal way to prevent erosion. The fencing is made with a synthetic mesh that allows water to filter through, but prevents soil or other materials from passing through. If you want to install a silt fence so that it will prevent contamination and erosion, follow the steps outlined below.

STEP 1

Prepare the area. Lay out your silt fence by placing stakes at each corner, and pulling a piece of string tight between the stakes. Posts should be placed 10 to 20 feet apart, depending on the application. In general, spacing the silt fence stakes around 12 to 16 feet is a good number to work with. Once your fence line has been laid, distribute the stakes around the perimeter so that you can ascertain you have the correct number available.

Dig a 4-8 inch (101.6-203.2 mm) deep trench. Use a shovel or backhoe and dig a 4-8 inch deep (101.6-203.2 mm), 4-inch wide (101.6 mm) trench on the bottom of a slope, where water is likely to pool. The trench should be curved or look like a J hook so that the water pools behind the fabric.

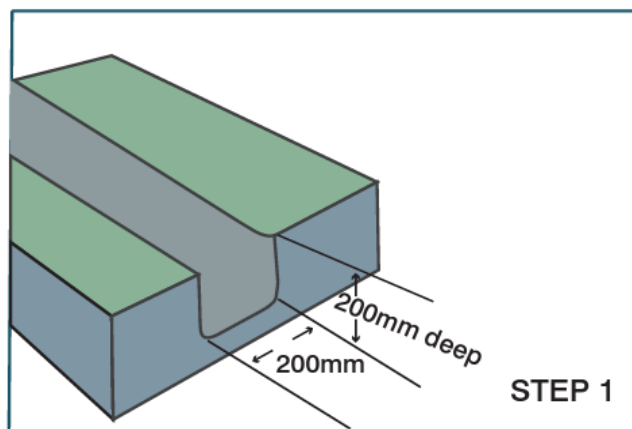

STEP 2

Hammer wooden stakes on the downslope of the hill.

Purchase 2-inch thick (50.8 mm), 4-foot long (1.21 m) posts from the hardware store. The stakes should be placed on the lower part of the trench. Use a 2 to 5 pound sledgehammer to drive in the stakes 1 foot (0.30 m) (304.8 mm) into the ground. Place each stake 3–5 feet (0.91–1.5 m) (1 - 1.5) meters next each other and run the wooden stakes across the entire length of the trench.

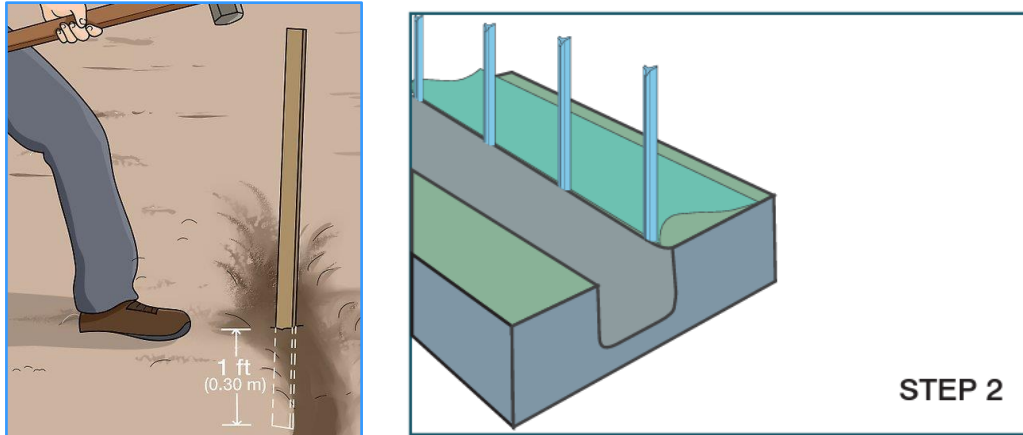

STEP 3

Place two stakes 1.5 feet (0.5 m) (45.72 cm) upslope on each end of the trench.

Place the fences on the side of the stakes facing where water flow will come from, and allow the first 8 to 12 inches of fence material to fold away from the fence, in the same direction. These posts will be on the end of your fence and will prevent the flow from bypassing the sides of the fence. Hammer these posts in like you did with the rest of your wooden stakes. Your fence should now look somewhat curved.

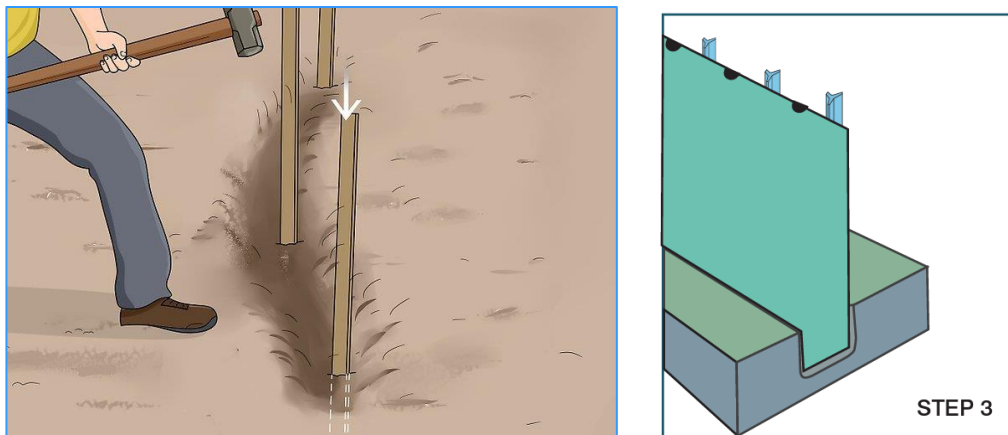

Step 4

Wrap and staple the silt fence around the stakes. You can purchase silt fence material at the hardware store or online. Measure the length of the desired fence so that you know how much silt fence fabric you'll need for the entire fence. Unroll the silt fence fabric and wrap it across the stakes so that the bottom of the fabric rests in the trench. As you wrap the silt fence onto one side of the stakes, use a heavy duty staple or hammer gun to attach the fabric to the stakes.

- Silt fence fabric is made of a special material that can filter out sediment while allowing water to flow.
- 100 feet (30.48 m) of fabric will cover most silt fences.

Make sure that the bottom flap is pointed up the hill, or in the direction where water will come from, and that it is smoothed out flat against the bottom of the trench.

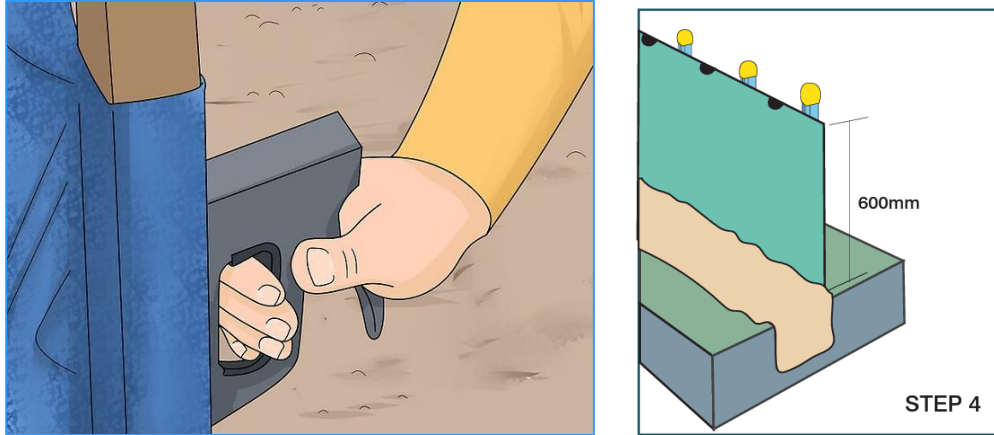

STEP 5

Fill the trench with dirt. Keep the bottom of the fabric in the trench while using a shovel to fill the trench back up with dirt. Begin by filling 3 to 6 inches in the bottom of the trench, to hold the flap in place. With that done, fill the hole with all of the soil you removed. It is not necessary to fill behind the stakes, but you can do so if there is excess dirt to be used, or if the ground is especially soft or wet. For best results, use a compactor, a flat square of metal on a straight wooden handle, and tamp the area you just filled. If available, a mechanical compactor can be used instead.

Your silt fence is complete once you've packed in all the dirt.

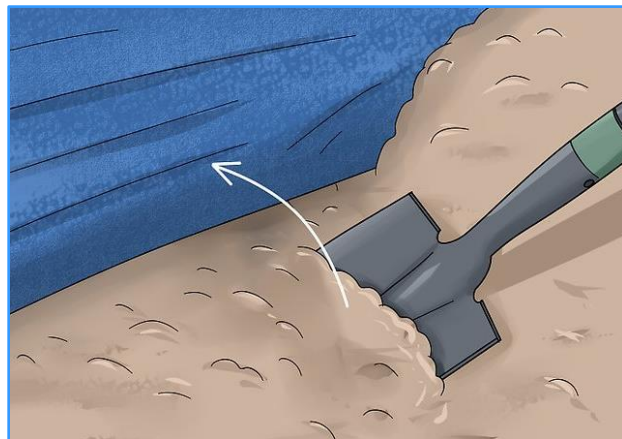

NOTES

Do not place silt fences across ditches or streams. Constantly running water is too much water for a silt fence to handle. Silt fences are best put in places where water pools, not where water flows.

Regular inspection of silt fence is required especially after each rainfall event. Make any necessary repairs and remove excessive silt deposits to reduce pressure on the silt fence.

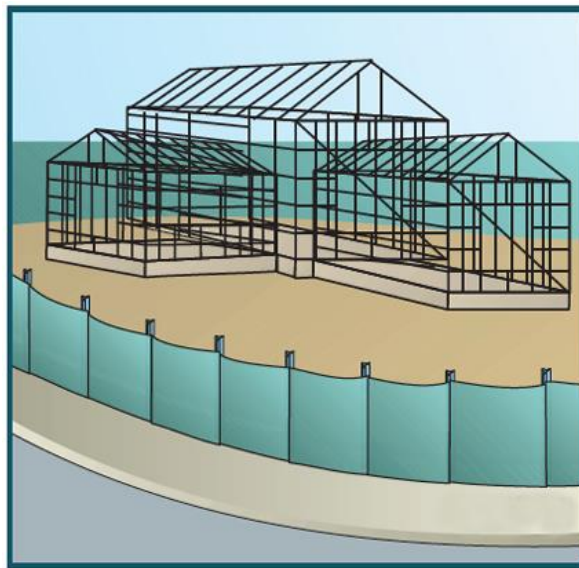

Maintaining a Silt Fence

- 1. Repair the fence if it breaks or bursts.** If there is a heavy rain, it's possible that your silt fence will break or burst. In this case, you should replace the fallen planks with new ones and ensure that there are no tears or rips in the fence fabric. If there is, purchase new fence fabric and replace the old fabric.

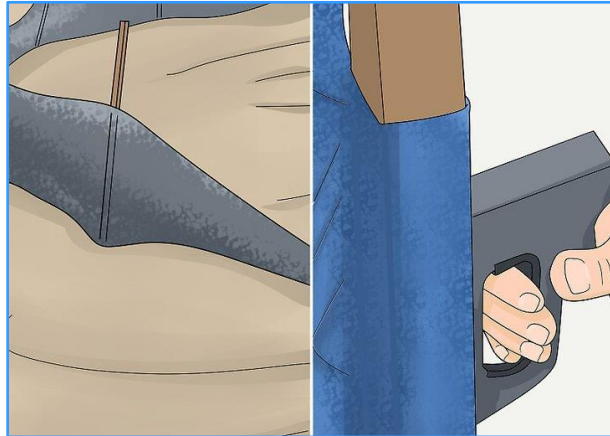

- 2. Monitor the fence to make sure the water pools.** If the water runs around the ends of the silt fence, it is virtually useless. Make sure that the water pools behind the fabric of the fence and gets filtered through the silt fence fabric. If it's not, you should evaluate your design and make sure that you placed stakes upslope on each end of the fence.^[5]
 - If water is running around the ends of the silt fence, you'll have to find a better place for it.

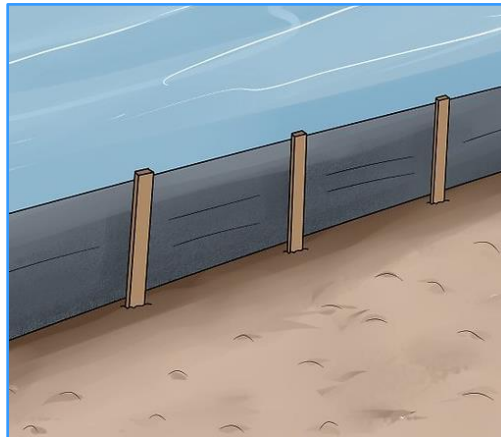

- 3. Inspect the fence before and after a heavy rainfall.** Look over the fence before and after a rainfall to ensure that it's working properly and that it's not damaged. Silt fences are most likely to break after heavy rain.

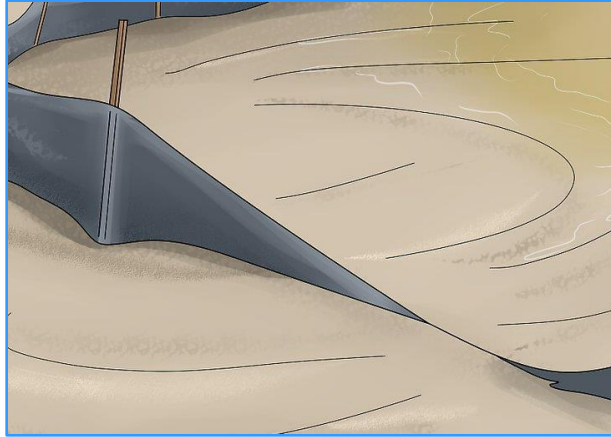

- 4. Replace the fence every 5 to 8 months.** Self-installed silt fences typically last anywhere from 5 to 8 months. After that point, the silt fabric will need to be replaced along with any moldy or damaged wooden stakes.

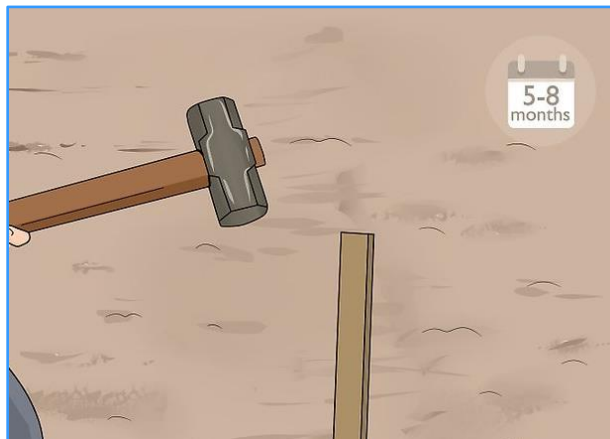

Silt Fence Installation Step-by-Step

① Top View

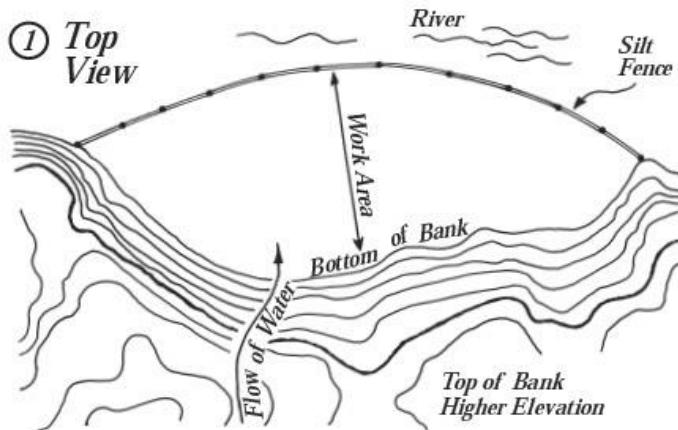

Prepare a stormwater pollution prevention plan. Set up silt fences according to terrain, soil and run-off consideration. Prevent soil migration by decreasing soil exposure, steep unvegetated slopes and construction time. Revegetate as soon as possible in the SAME SEASON.

①a Side View Detail

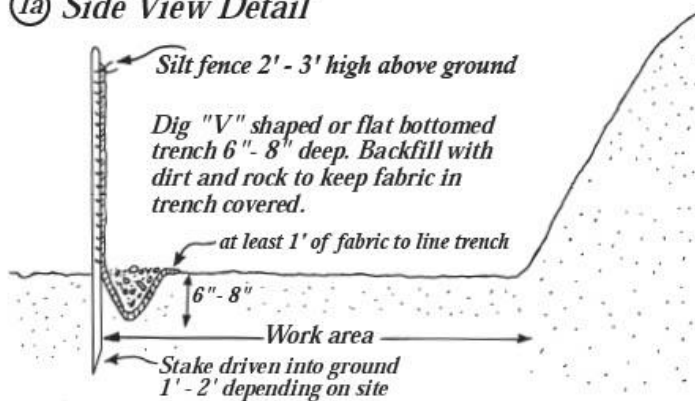

Monitor integrity of installed silt fence and remove sediment before it reaches 1/3 the height of the silt fence. It is especially important to monitor during and after rain and break-up events.

①b Front View Detail (One Section of Silt Fence)

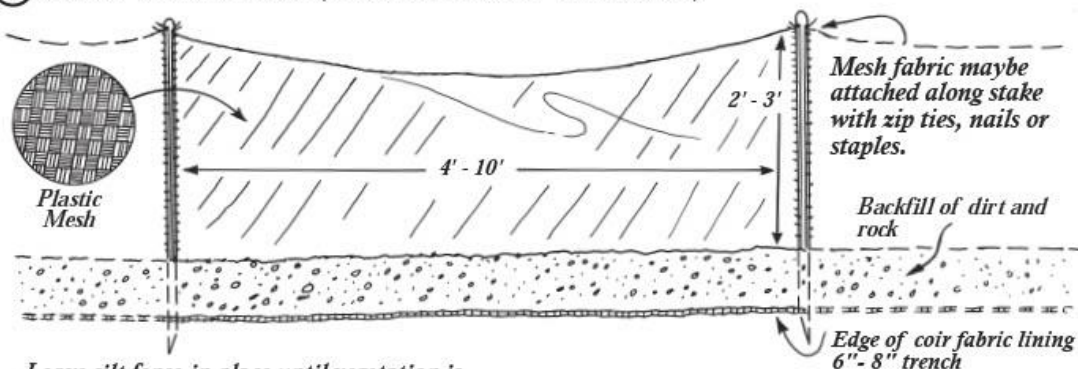

Leave silt fence in place until vegetation is established and sediment is stabilized.